



Montageanleitung

Rollgestell

oder

Fahrbarer Akku-Schrank

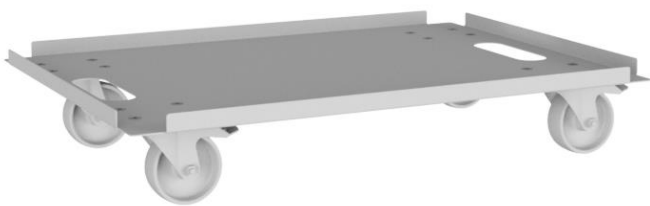

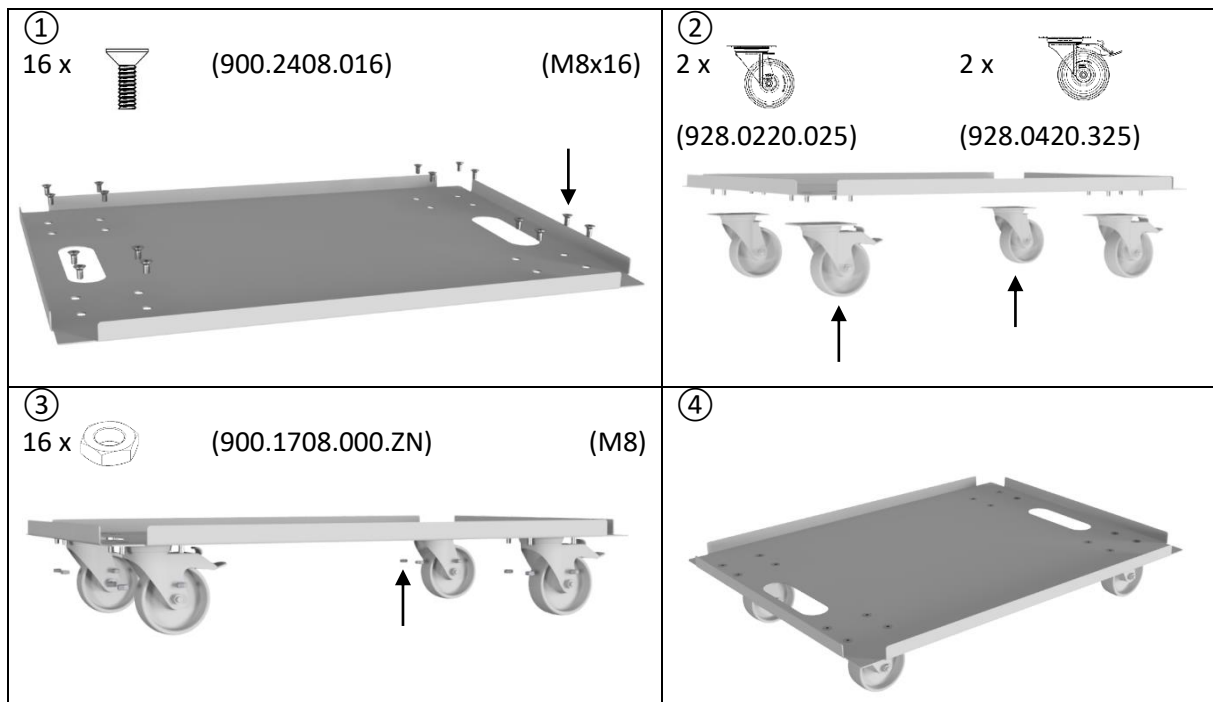

Rollgestell

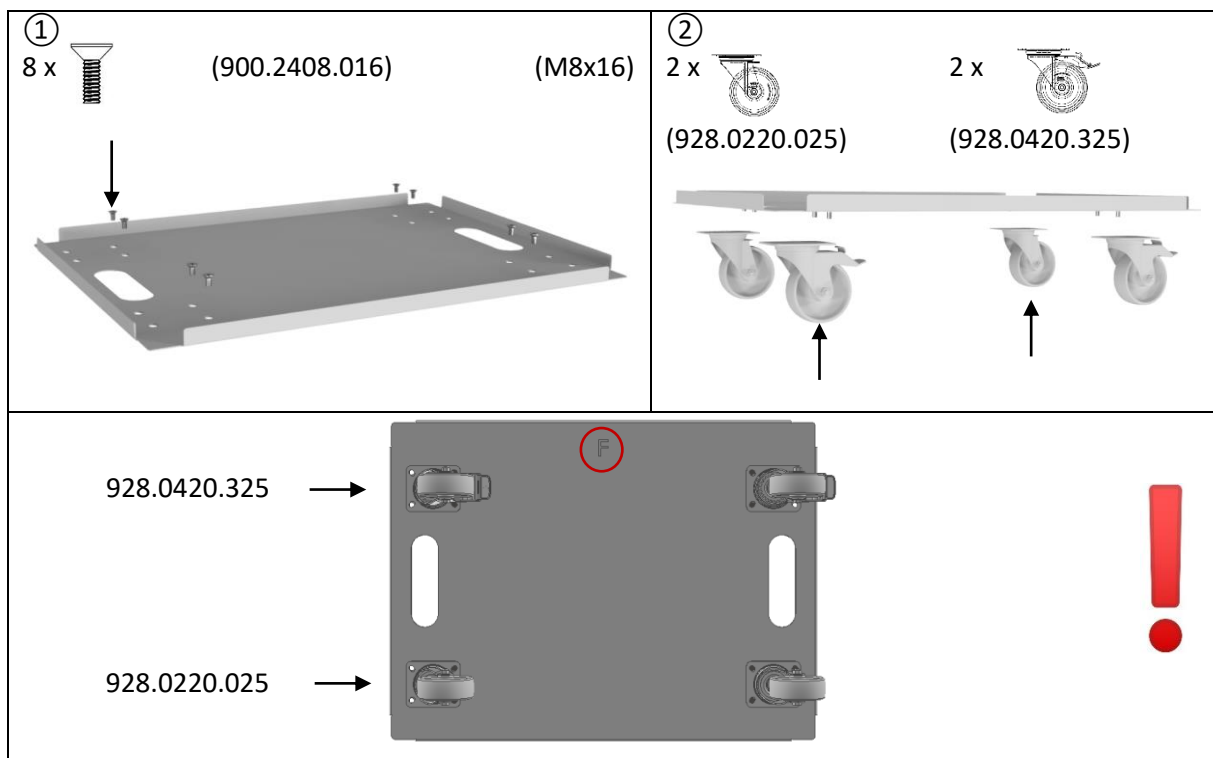

Fahrbarer Akku-Schrank





③
8 x  (900.1708.000.ZN) (M8)

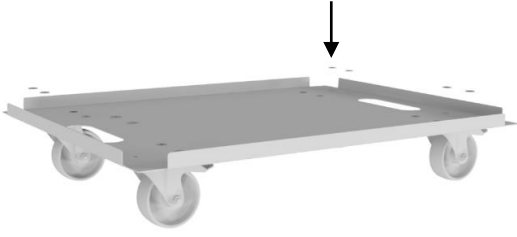

④
8 x  (900.4606.000.ZN) (M6)



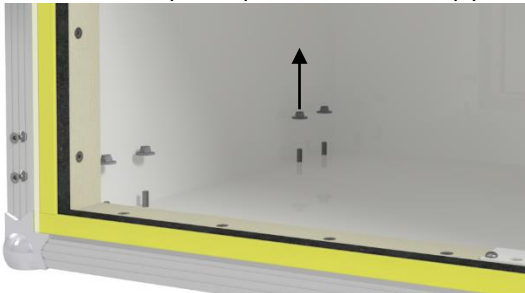

⑤
8 x  (900.4606.000.ZN) 8 x  (M6) (900.2006.000.ZN) 8 x  (900.1506.024.ZN) (M6x40)



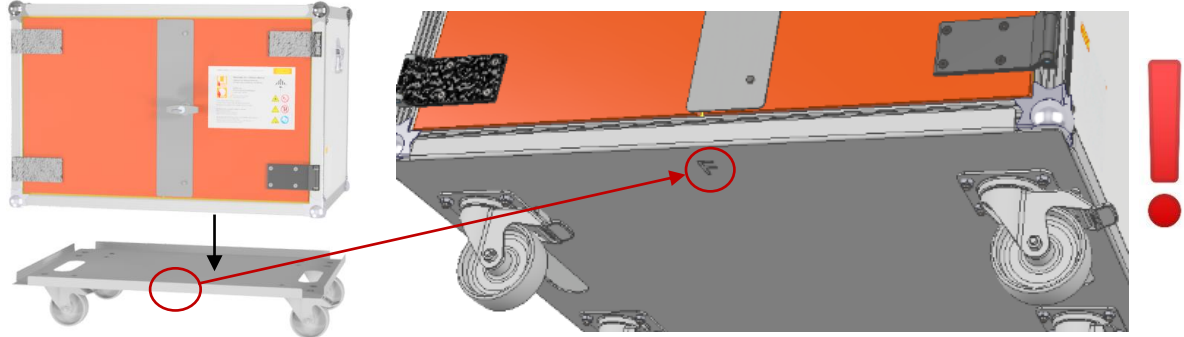

⑥



⑦
8 x  (900.1506.025.ZN) (M6x45)



⑧
8 x  (900.4606.000.ZN) 8 x  (M6) (900.2006.000.ZN)





D	Rollgestell	Fahrbarer Akku-Schrank
GB	Trolley	Mobile Battery-Cabinet
F	Chariot	Armoire batterie mobile
NL	Trolley	Mobiele batterijkast